

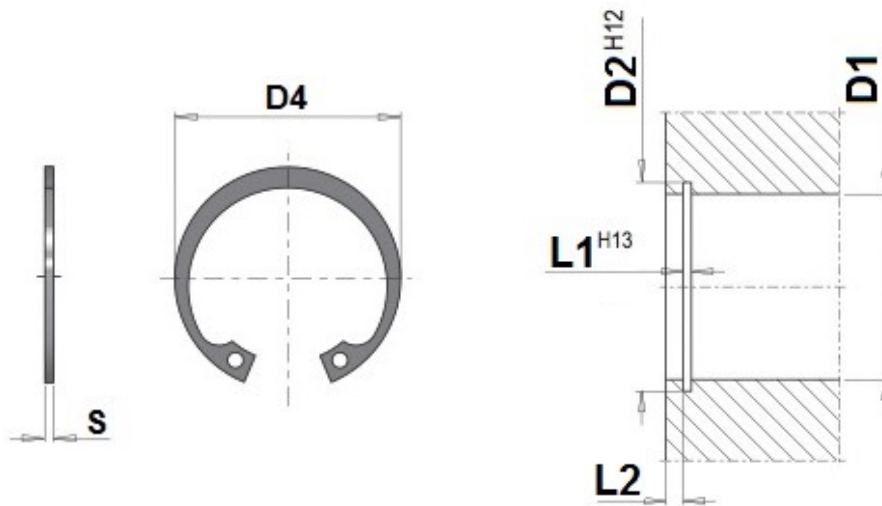

Seeger circlip ring Din 472

 = Verpackungseinheit / packing unit

Nr. / No.	D1	D2	D4	S	L1	L2 min.	
K6105 - 10	10	10,4	10,8	1,00	1,10	0,6	20
K6105 - 12	12	12,5	13,0			0,8	
K6105 - 14	14	14,6	15,1			0,9	
K6105 - 16	16	16,8	17,3			1,2	
K6105 - 17	17	17,8	18,3				
K6105 - 18	18	19	19,5			1,5	
K6105 - 20	20	21	21,5				
K6105 - 22	22	23	23,5				
K6105 - 24	24	25,2	25,9	1,20	1,30	1,8	
K6105 - 26	26	27,2	27,9				
K6105 - 30	30	31,4	32,1			2,1	
K6105 - 32	32	33,7	34,4			2,6	
K6105 - 36	36	38	38,8	1,50	1,60	3,0	
K6105 - 40	40	42,5	43,5	1,75	1,85	3,8	
K6105 - 42	42	44,5	45,5				
K6105 - 48	48	50,5	51,5				
K6105 - 55	55	58	59,2	2,00	2,15	4,5	
K6105 - 60	60	63	64,2				
K6105 - 72	72	75	76,5	2,50	2,65		
K6105 - 85	85	88,5	90,5	3,00	3,15	53	