

**3047 Gleitführungsbuchse mit Flansch**  
 Stahl, mit Festschmierstoff

**Sliding guide bush with flange**  
 steel, with solid lubricant

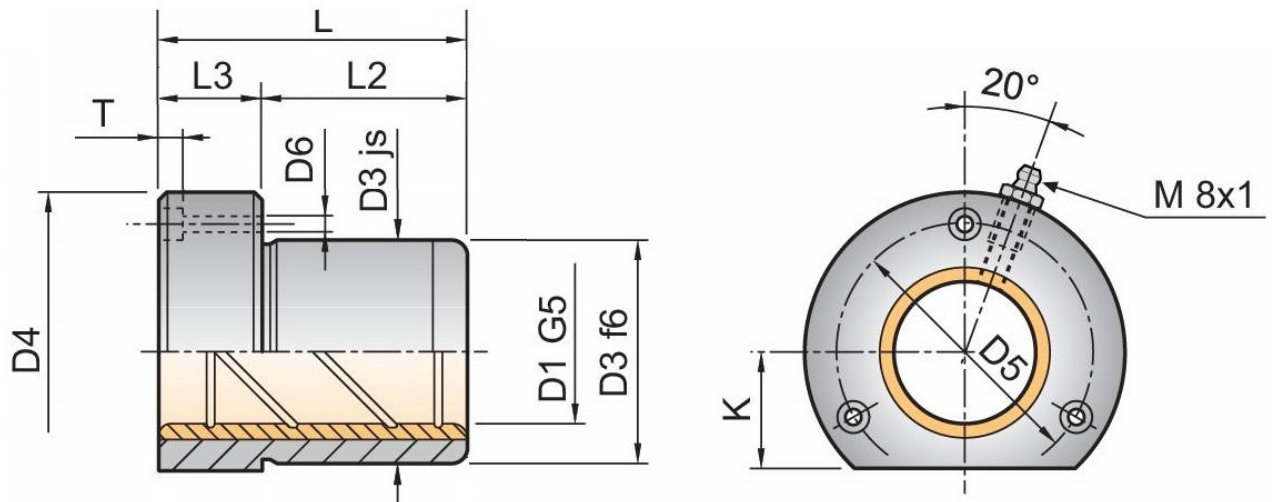

Material: 1.7131 / 61-63 HRC

Best.Nr. Order No	D1	L	L2	L3	D3	D4	D5	D6	T	K
3047-19x038	19	38	23	15	32	50	40	4,5	4,6	18
3047-19x045		45	30							
3047-19x052		52	37							
3047-20x038	20	38	23							
3047-20x045		45	30							
3047-20x052		52	37							
3047-24x038	24	38	23		40	63	50	5,5	5,7	23
3047-24x055		55	30	25						
3047-24x062		62	37							
3047-25x038	25	38	23	15						
3047-25x055		55	30	25						
3047-25x062		62	37							
3047-30x045	30	45	30	15	48	72	58			28
3047-30x062		62	37	25						
3047-30x072		72	47							
3047-32x045	32	45	30	15						
3047-32x062		62	37	25						
3047-32x072		72	47							

**3047 Gleitführungsbuchse mit Flansch**  
 Stahl, mit Festschmierstoff

**Sliding guide bush with flange**  
 steel, with solid lubricant

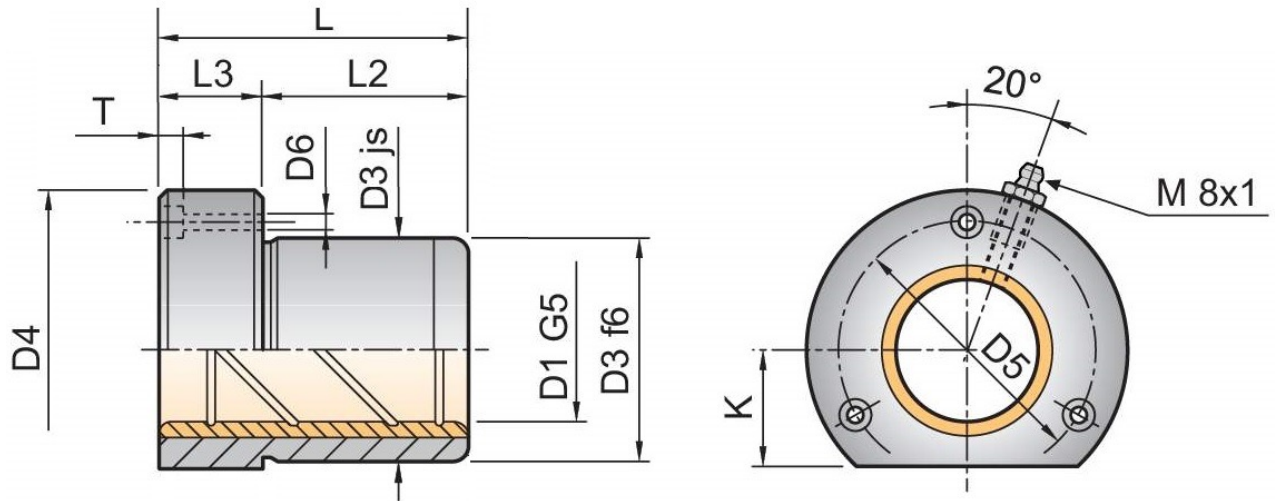

Material: 1.7131 / 61-63 HRC

Best.Nr. Order No	D1	L	L2	L3	D3	D4	D5	D6	T	K
3047-38x055	38	55	30	25	58	85	70	6,5	6,8	33
3047-38x067		67	37	30						
3047-38x077		77	47							
3047-40x055	40	55	30	25						
3047-40x067		67	37	30						
3047-40x077		77	47							
3047-48x062	48	62	37	25	70	104	86	9	9	38
3047-48x089		89	47	42						
3047-48x102		102	60							
3047-50x062	50	62	37	25						
3047-50x089		89	47	42						
3047-50x102		102	60							
3047-60x089	60	89	47		85	120	100			46
3047-60x102		102	60							
3047-63x089	63	89	47							
3047-63x102		102	60							
3047-80x125	80	125	75	50	105	148	125	11	11	56